

# Bagging Units

## FARMING

**Bagging Units** are used for the dosing and packaging of compound feeds, premixtures or mineral feeds. The goods to be packaged are uniformly conveyed with a screw feeder into a bagging scale, where units from 2 to 60 kg can be weighed with 0.05-kg division. Due to preset index values for fine-coarse dosing, the frequency is switched from a higher to a lower value by a frequency converter. When the index weight is reached, the dosing valve of the screw feeder is closed by means of a pneumatic cylinder and the drive is switched off. Then the bag to be filled is attached to the bagging funnel of the unit, which is equipped with a bag clamp. After filling, the bag can be moved on by means of a belt conveyor (conveying distance approx. 3 m) to where it will be closed on top with a hand-held stitching machine. The control of the unit is included in the delivery. The performance of the unit depends on the operator.



# Bagging Units

## FARMING

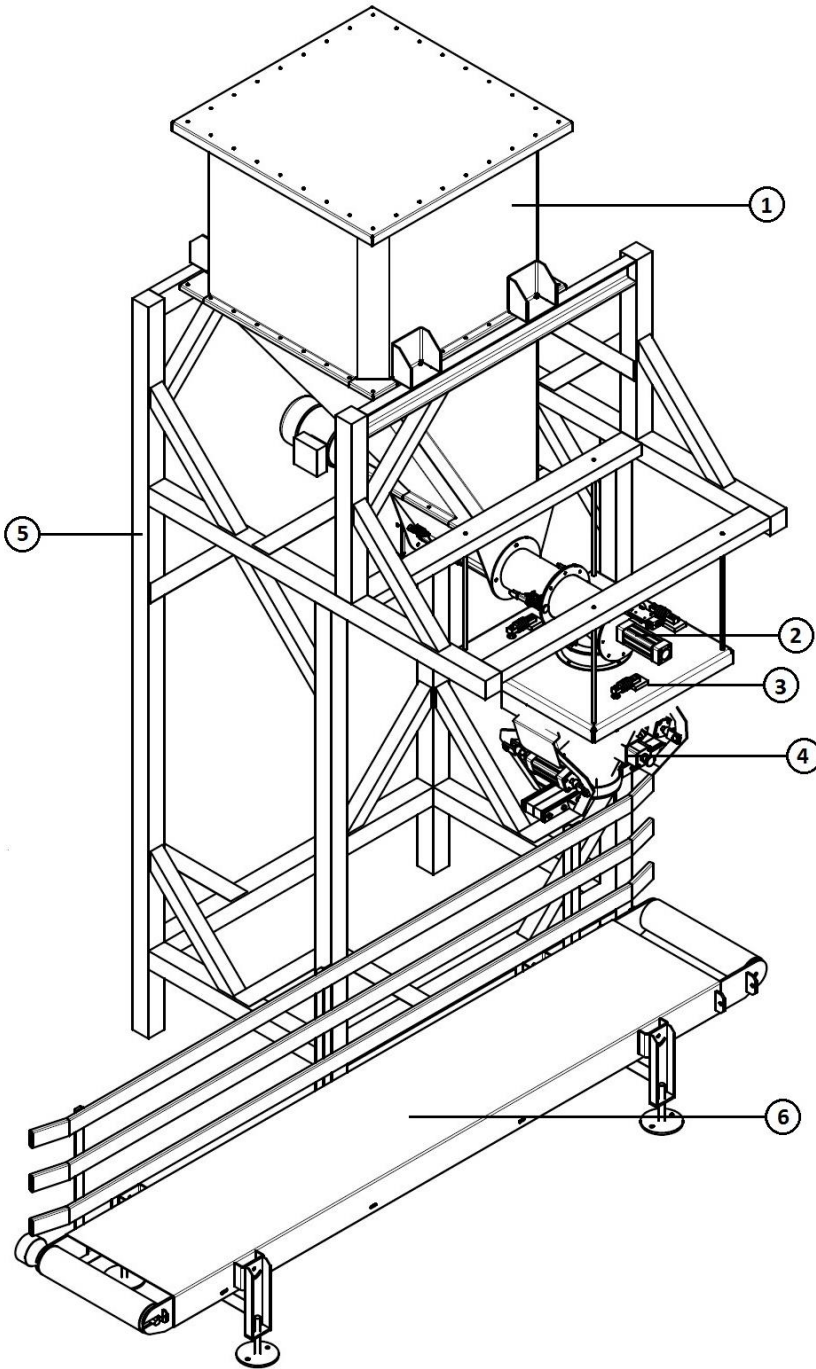

Item	Description
1	Pre bin
2	Dosing auger
3	Load cell
4	Clamp for bag fixing
5	Frame
6	Conveyor belt

