

Compact Plants

FARMING

Compact plants are especially well suited to the production of small quantities of prepared feed (up to 0.5 t/h). The raw materials are put into the infeed funnel, which has a fill volume of 100 litres, and are milled by the hammer mill which has a 7.5 kW v-belt drive and then are fed further to the mixer. Additional pre-mixes or minerals can be added via the manual feeding station. The emptying of the mixer (2.2 kW motor) is done via the side-mounted outlet. This outlet is connected directly to the mixing screw conveyor through which a higher rate of emptying is achieved. As an option, the hand slider of the discharge can also be operated by motor.

All advantages at a glance

- ✓ Space saving plant in a robust all-steel design with supporting frame
- ✓ Driven by V-belts
- ✓ Cover and filter for low dust emissions
- ✓ Protective grill and permanent magnet in the infeed funnel
- ✓ Operation monitoring through an inspection glass in the mixer
- ✓ Discharge via hand slider
- ✓ Simple control

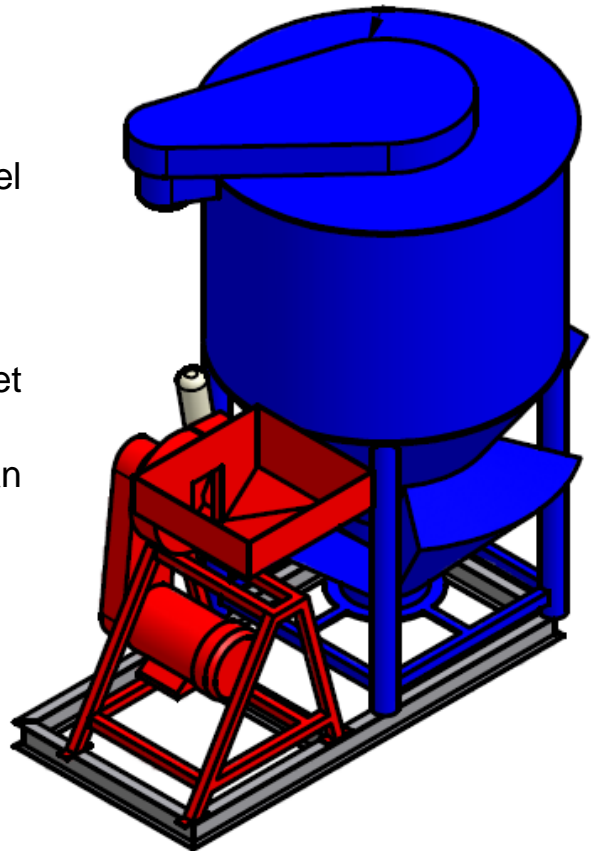

Compact Plants

FARMING

Item	Description
1	Infeed funnel
2	Mill
3	Filter
4	Mixer
5	Manual infeed
6	Outlet with hand slider
7	Supporting frame

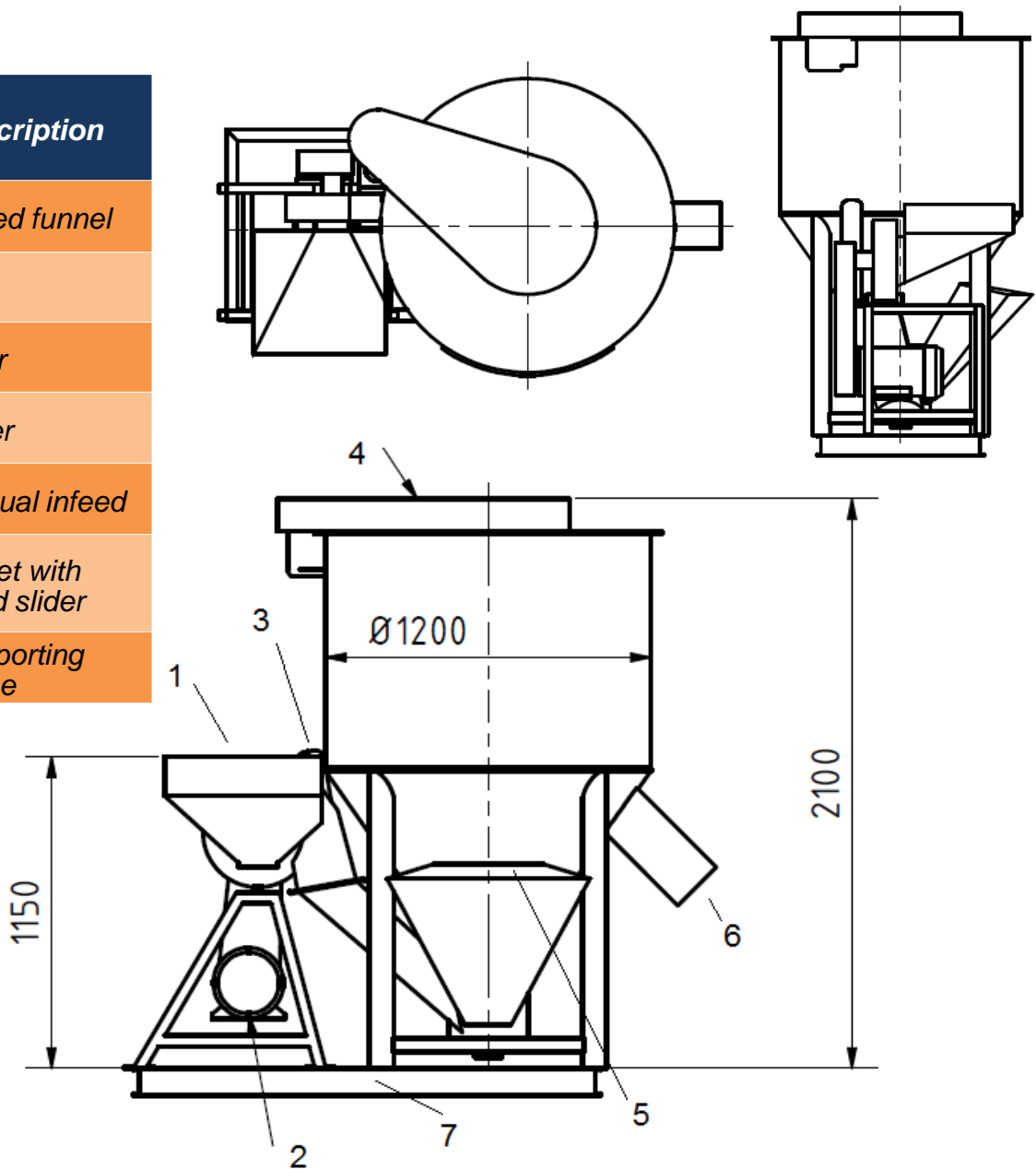

Compact Plants

FARMING

Photographs

